



Heavy Duty End Trucks

To Build Top Running, Underhung or Gantry Cranes

North American end trucks are heavy duty equipment for building rugged, long lasting industrial cranes. They are designed and built to provide decades of reliable service in demanding applications. Available in twin motorized, hand geared, or push models.

Standard Features

- Built to class “D” heavy duty CMAA standards for multiple shift use, not moderate duty class “C” standards.
- Gentle mechanical braking is provided to prevent load from swinging when crane stops.
- Top running end trucks have wide treads to accommodate some rail misalignment, and underhung end trucks have combination tread wheels to ride on both flat and tapered flanges.
- Electric soft starts (standard at 7½ ton or greater capacity) gently accelerate the crane, preventing the load from swinging.
- Reversing controls are low voltage (110V) for safety, and fused for protection.
- No maintenance double sealed ball bearings with life time lubrication.

Optional Features

- OSHA recommended rubber bumpers
- Dual travel speed
- Variable travel speed
- 25, 45, 65, 85, 100, 125, 150, or 200 FPM travel speed
- Weather proofing
- Cold weather protection
- Soft starts, soft stops or electric brakes
- Available in money saving “kit form”

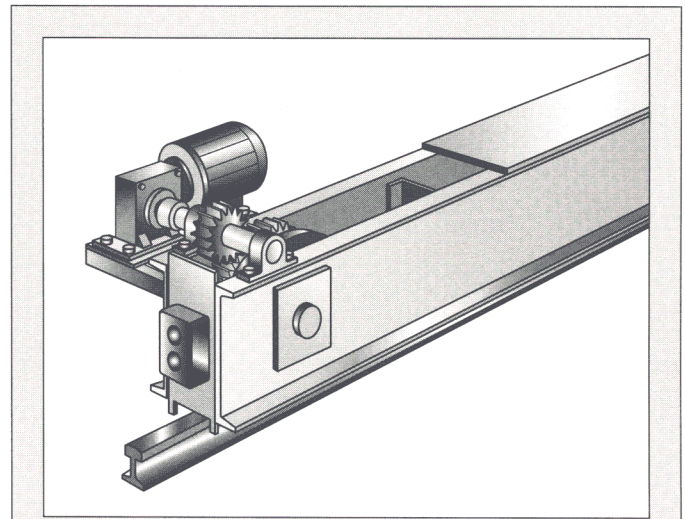

Top Running End Truck

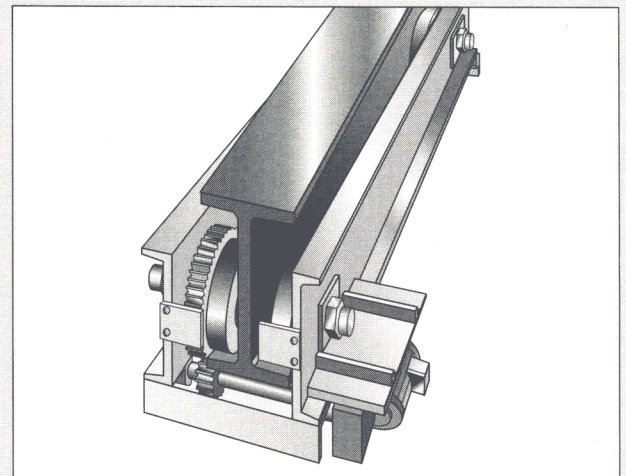

Underhung End Truck

Included with every order at no charge:

1. Step-by-step crane assembly manuals
2. Toll-free 800 help line
3. Recommended cross girder size
4. 2 year warranty—double the industry norm
5. Nationwide service
6. Runway designs, drawings
7. Complete electrical wiring diagram
8. 2 button pendant (upgradable to 8 buttons) and reversing controls